

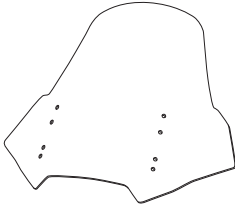

# HONDA ST1300 PAN EUROPEAN

REF 5995

CÚPULA TOURING - TOURING SCREEN - TOURENCHIEBE FÜR



ID	PIEZA/PART	DESCRIPCIÓN	DESCRIPTION	QTY	REF
1		Cúpula touring	Touring screen	1	5995A/H/WM3
2		Casquillo con valona Ø15 x Ø9 x 7,5	Ø15 x Ø9 x 7,5 bush with flange	4	CASQUI-1A---324
3		Arandela nylon M10 DIN433 (Ø18 x Ø10,5 x 1,6)	M10 DIN433 Nylon washer (Ø18 x Ø10,5 x 1,6)	4	ARAND-----650

# HONDA ST1300 PAN EUROPEAN

## INSTRUCCIONES DE MONTAJE - MOUNTING INSTRUCTIONS - MONTAGEANLEITUNG

**1**

DISASSEMBLY  
DESMONTAJE

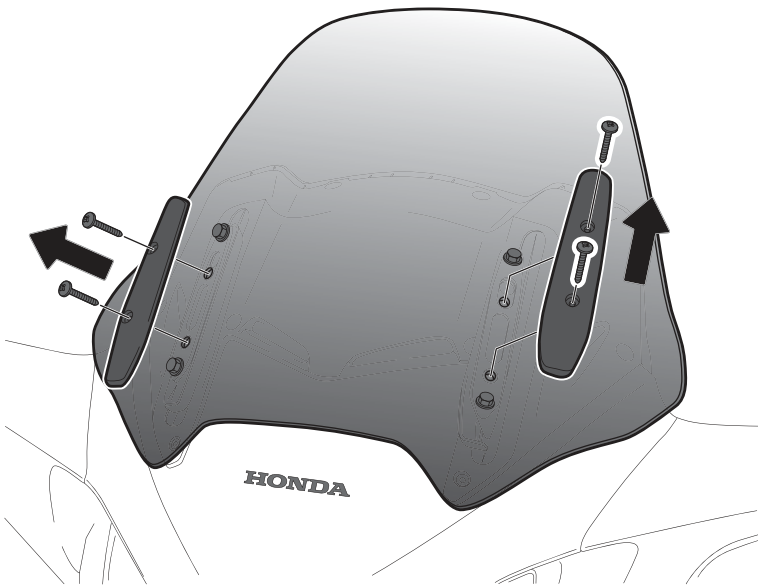

**2**

DISASSEMBLY  
DESMONTAJE

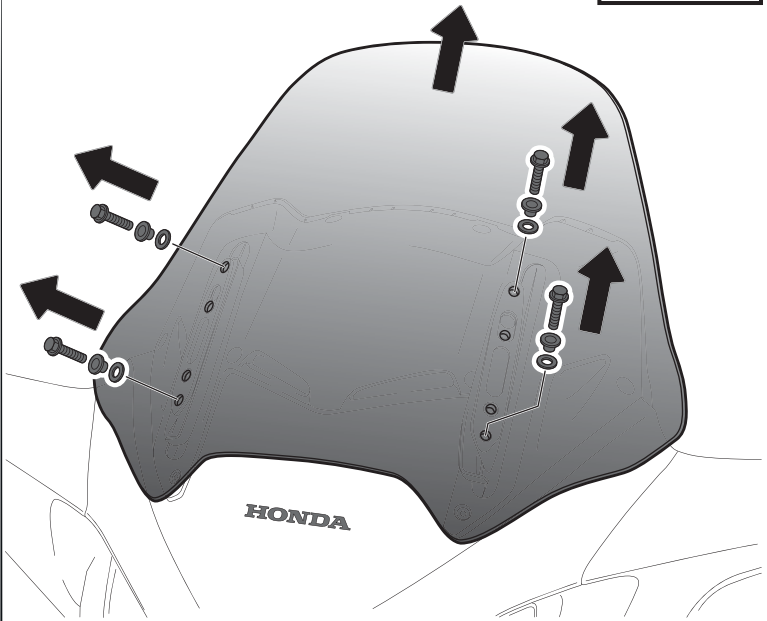

**3**

ASSEMBLY  
MONTAJE

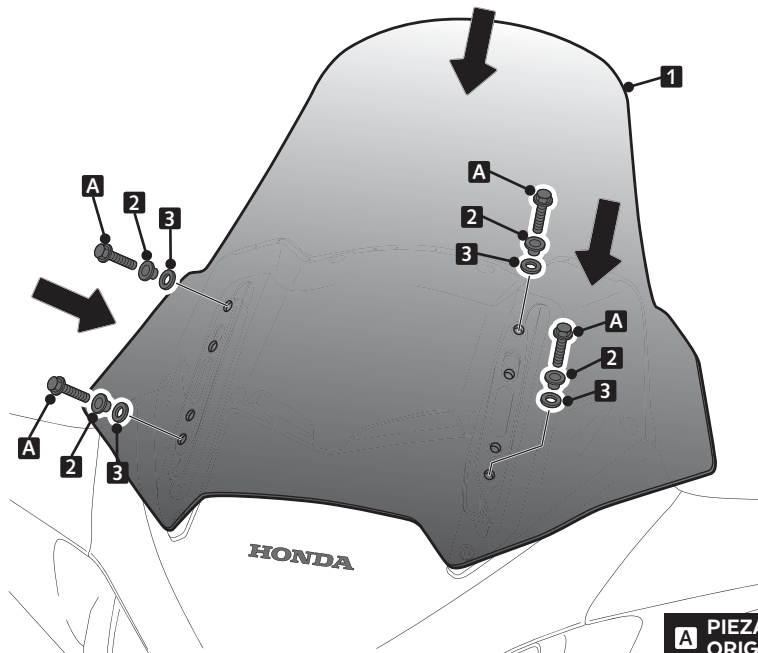

**4**

ASSEMBLY  
MONTAJE

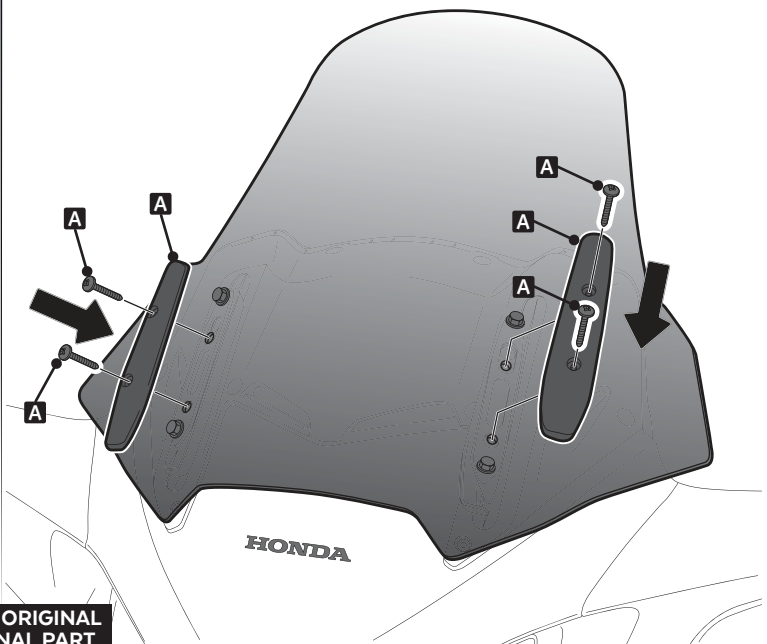

**A** PIEZA ORIGINAL  
ORIGINAL PART

## VISERA MULTIREGULABLE MULTI-ADJUSTABLE VISOR

CÚPULA TIPO  
TYPE WINDSCREEN **A**



CÚPULA TIPO  
TYPE WINDSCREEN **B**



CÚPULA TIPO  
TYPE WINDSCREEN **C**



Ref.: 6007

Ref.: 5852

Ref.: 5853

Ahumado/Smoke

Transparente/Clear

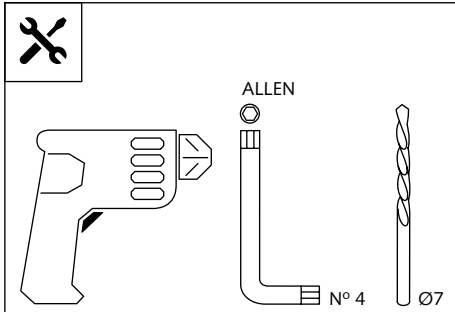

1 persona  
1 person



15 min

Fácil - Easy

Media-Intermediate

Difícil-Difficult

**Nota/Note:**

Si la visera se suministra con la cúpula Puig, no será necesario realizar los agujeros por que ya vienen incorporados.

If the visor is supplied along with the windscreen, the windscreen will come factory-drilled so no drilling is necessary.

ID.	PIEZA / PART	DESCRIPCIÓN	DESCRIPTION	QTY.
1		Visera	Visor	1
2		Plantilla	Template	1
3		Mecanismo multiregulable	Multi-adjustable mechanism	2
4		Tapeta	Cap	4
5		Tornillo rosca plástico M6x12	Plastic thread fastener M6x12	8

# VISERA MULTIREGULABLE MULTI-ADJUSTABLE VISOR

INSTRUCCIONES DE MONTAJE - MOUNTING INSTRUCTIONS - MONTAGEANLEITUNG

TIPO/TYPER A - TIPO/TYPER A - TIPO/TYPER A

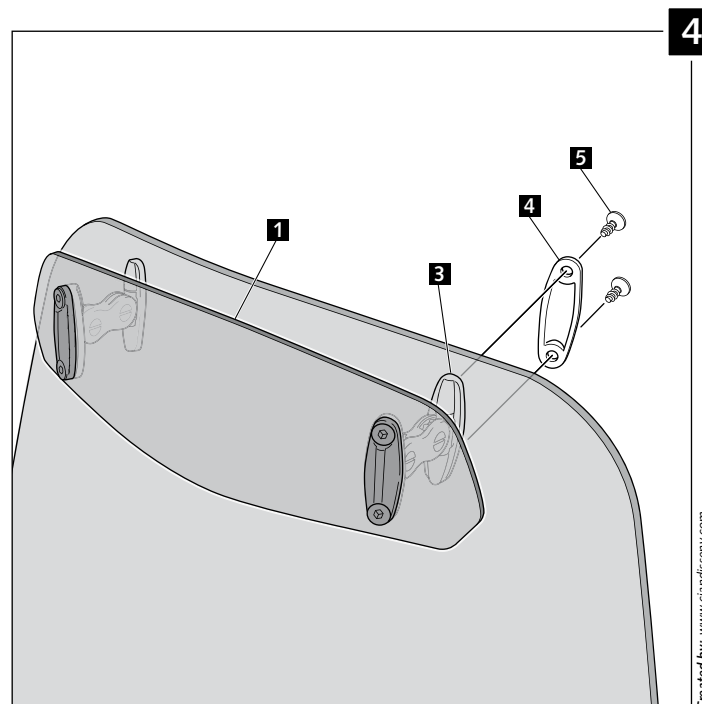
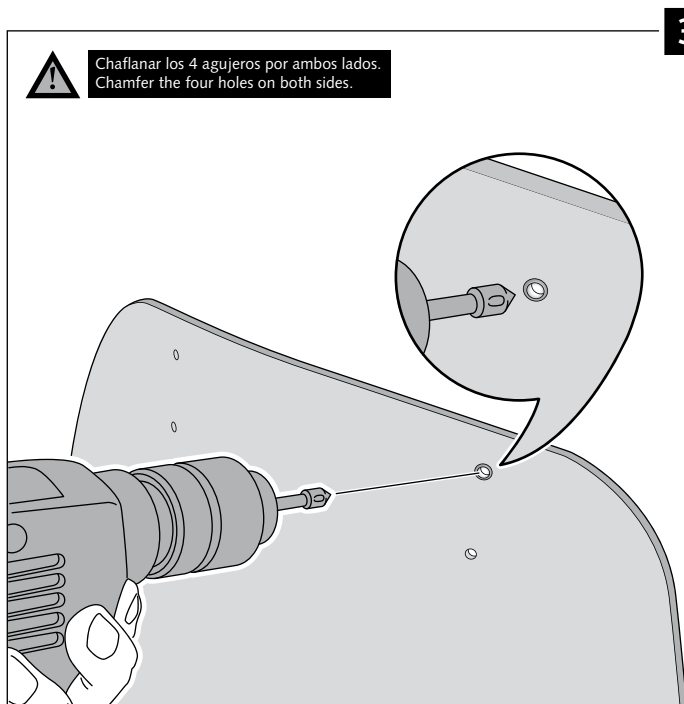
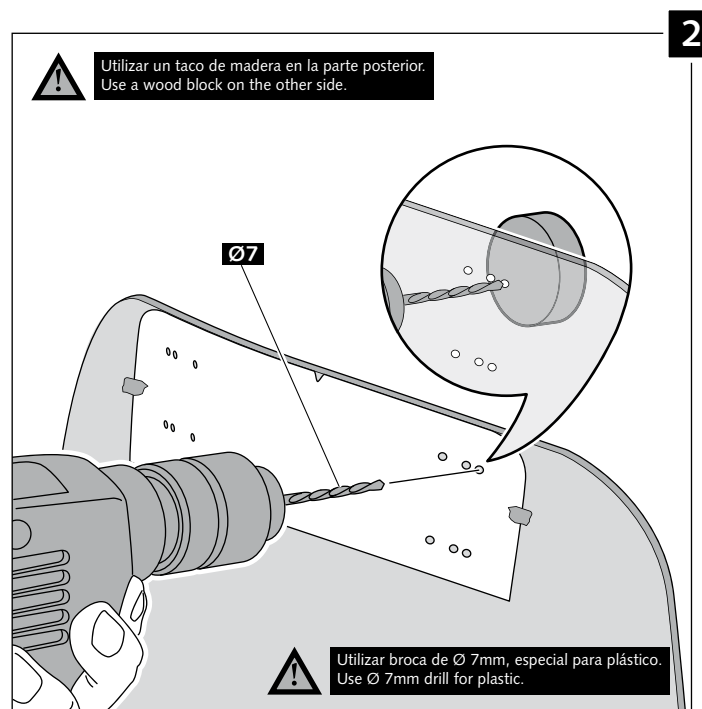
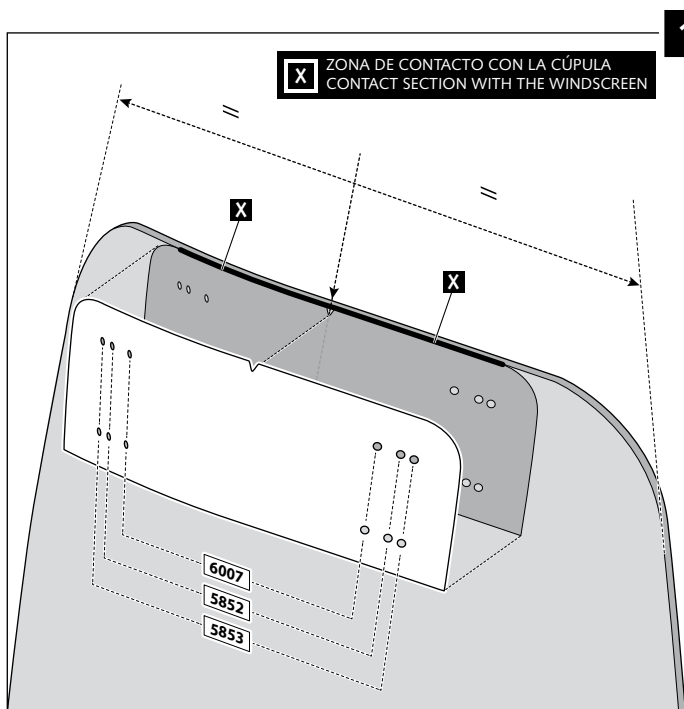

# VISERA MULTIREGULABLE MULTI-ADJUSTABLE VISOR

INSTRUCCIONES DE MONTAJE - MOUNTING INSTRUCTIONS - MONTAGEANLEITUNG

TIPO/TYPER B - TIPO/TYPER B - TIPO/TYPER B

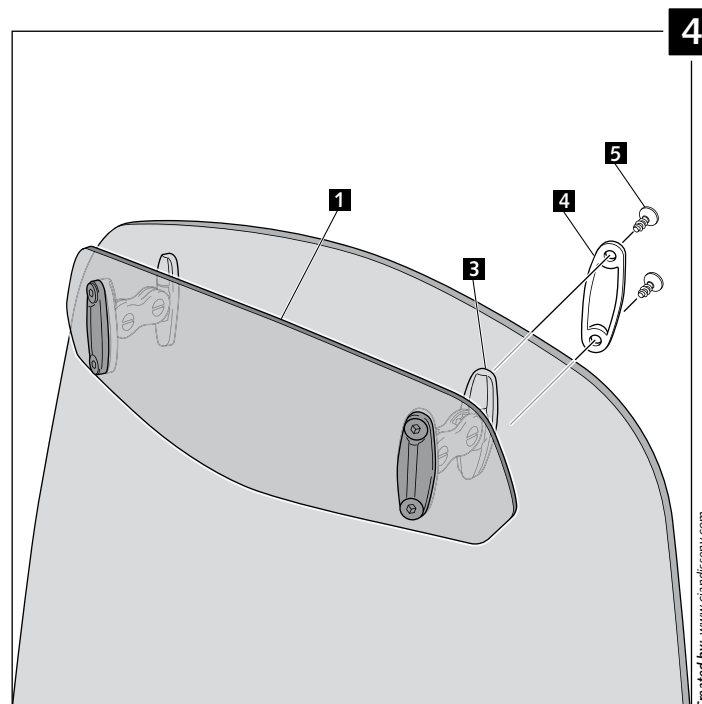
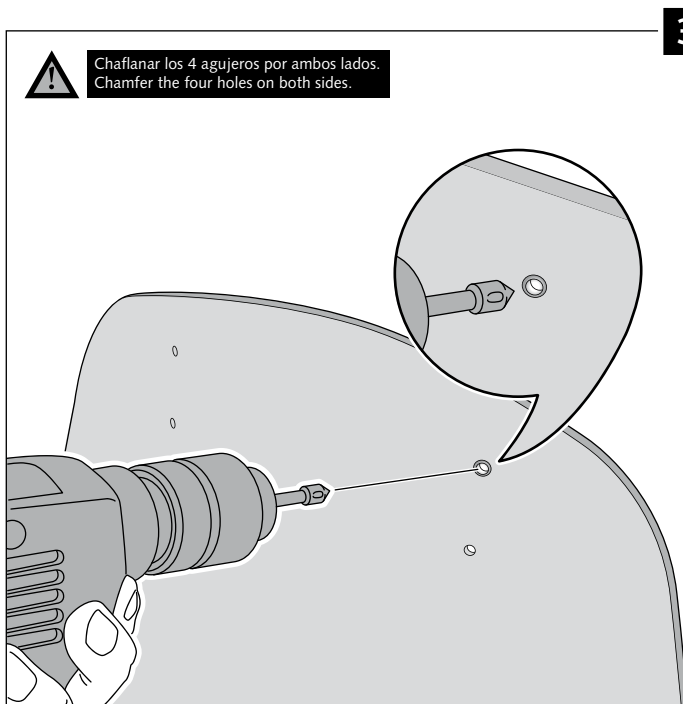
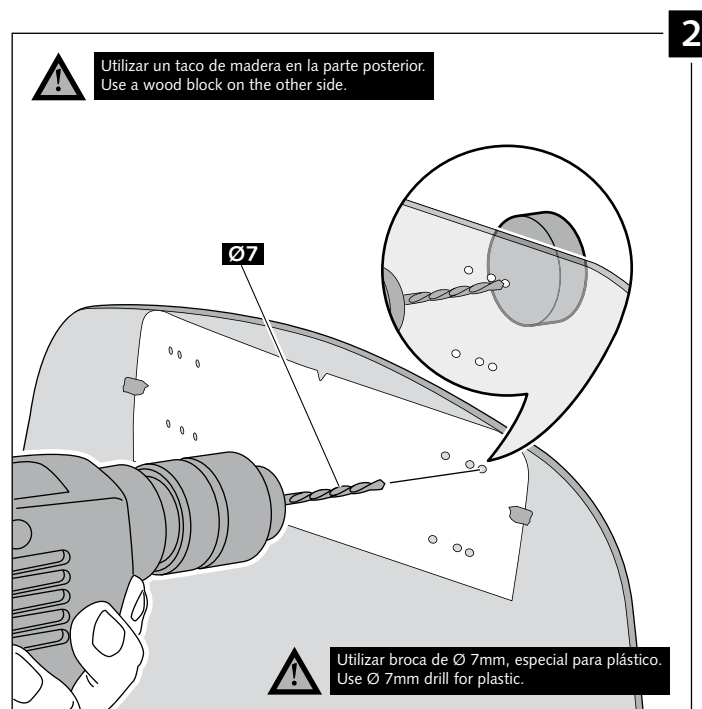
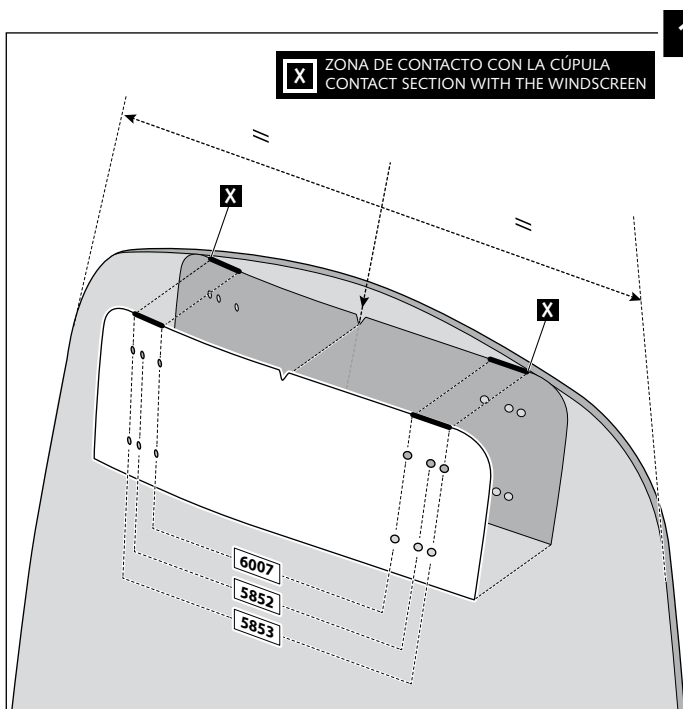

# VISERA MULTIREGULABLE MULTI-ADJUSTABLE VISOR

INSTRUCCIONES DE MONTAJE - MOUNTING INSTRUCTIONS - MONTAGEANLEITUNG

TIPO/TYPER C - TIPO/TYPER C - TIPO/TYPER C

